

Performance Chart

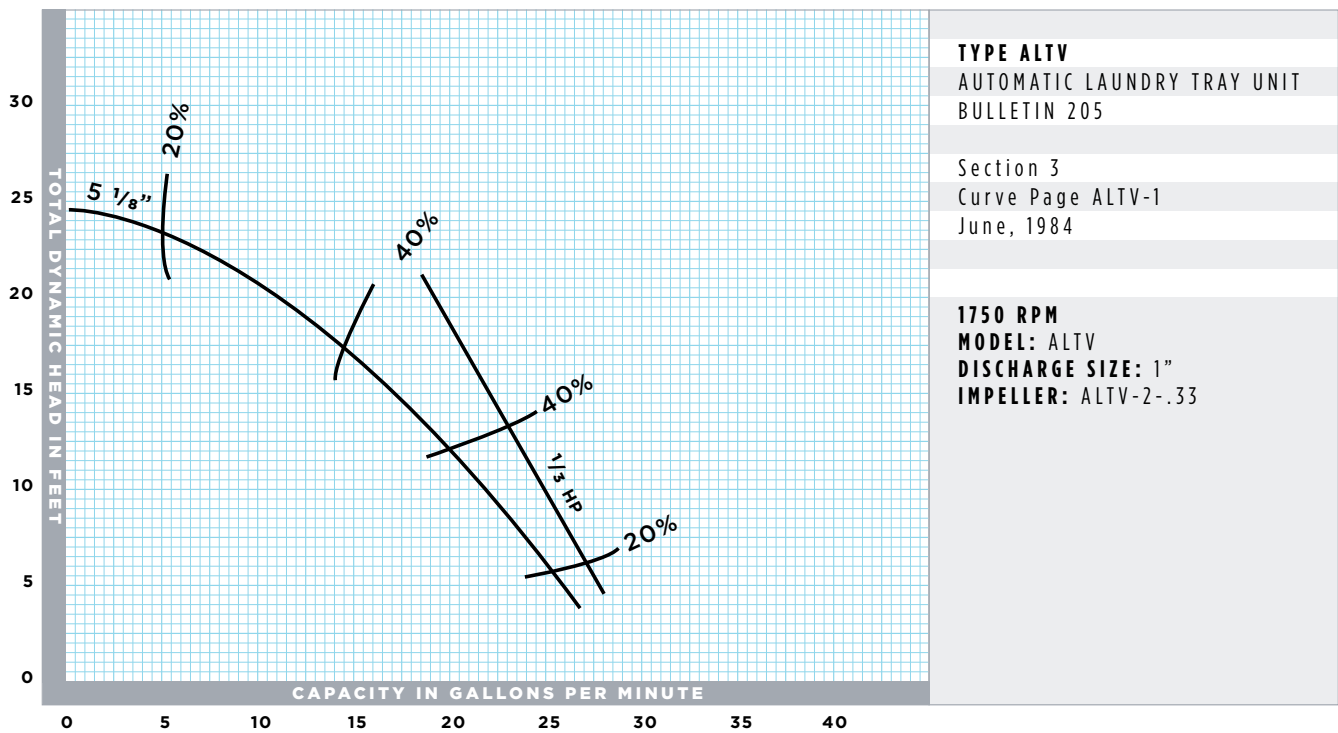

Supplemental # 0210

ADDRESS: 1144 Utica Avenue, Brooklyn, NY 11203 TEL: (718) 451-2000 URL: federalpumps.com

All images and information contained in this booklet are the sole property of The Federal Pumps Corporation, and may not be reproduced without written permission.

Parts List & Diagram

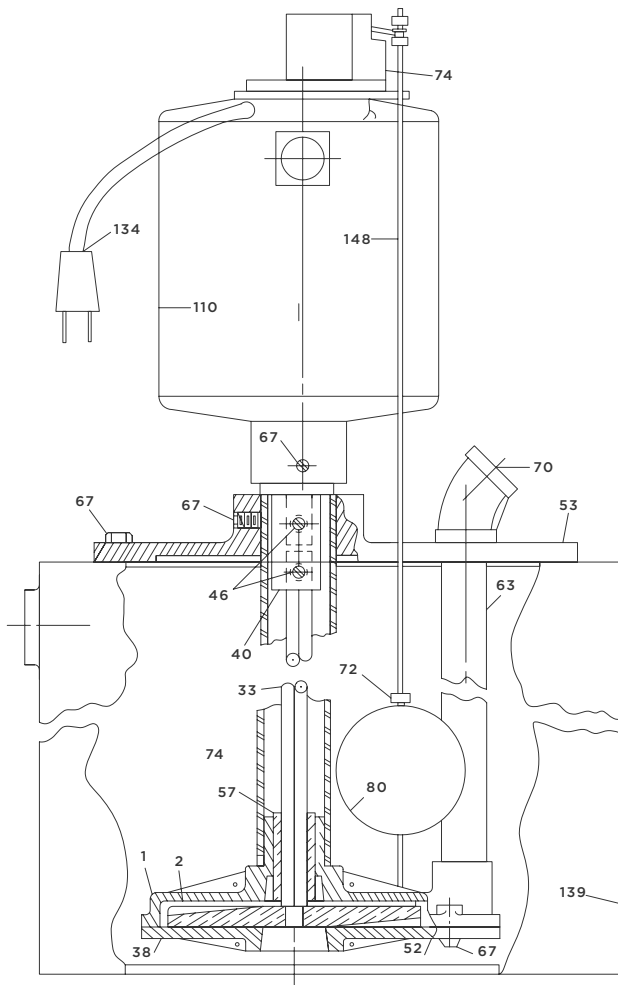

PARTS LIST

NUMBER	NAME	REQD.	MATERIAL
1	PUMP CASING	1	CAST IRON
2	IMPELLER	1*	ALUMINUM
33	SHAFT	1*	ST.ST.
38	SUCTION PLATE	1	CAST IRON
40	COUPLING	1*	STEEL
46	ADJUSTING SCREW	2*	STEEL
52	LOCK WASHER	5	ST.ST.
53	SUPPORT PLATE	1	ALUMINUM
56	SUPPORT LEG	1	STEEL
57	PUMP BEARING	1*	BRONZE
63	DISCHARGE PIPE	1	GALV. STEEL
67	SUPPORT PLATE SCREW	3	CADMIUM STEEL
67	MOTOR SET SCREW	3*	STEEL
67	SUPPORT LEG SET SCREW	1	STEEL
67	MACHINE SCREW	5	BRASS
70	DISCHARGE ELBOW	1	GALV. MALL. IRON
72	FLOAT STOP	4	ALUMINUM
74	FLOAT SWITCH	1*	VARIOUS
80	FLOAT	2*	PLASTIC
110	MOTOR	1	VARIOUS
134	POWER CHORD PLUG	1*	VARIOUS
139	TANK	1	STEEL
148	FLOAT CABLE	1*	BRASS

* Recommended spare parts to be carried in stock.